

Ref. No.	Part No.	Description	Qty.	Ref. No.	Part No.	Description	Qty.
1	37331-105	End Plate (non CPR unit)	1	27	342-111	Oil Seal	1
2	432-12	End Plate Gasket	1	28	432-2-1	Flywheel 20", 2-B Groove	1
3	NCB-303-1	Oil Filler Plug	1	29	432-326	Flywheel Retaining Washer	1
4	SS-14	Hex Head Cap Screw 5/16 -18 x 1"	10	30	SS-1508	Lock Washer Medium 5/8"	1
5	SS-9924	3/8 " NPT Pipe Cap	1	31	SS-6883	Hex Head Cap Screw 5/8-18 x 1 1/2"	1
6	SS-2108	3/8 " x 2 Nipple	1	32	SS-10482	Square Key 3/8" x 2"	1
7	225-6	Screw	2	33	445-474	Bearing Insert	2
8	37137-104	Crankcase	1	34	445-4110-3	Rod & Cap Assy.	2
9	445-327	Cylinder to Crankcase Gasket	1	35	445-4112-1	High Pressure Piston & Pin Assy.	1
10	SS-48	Hex Head Cap Screw 1/2" - 13 x 1"	6	36	SS-9946	Lock Washer	4
11	447-325	Cylinder	1	37	SS-9947	Connecting Rod Bolt	4
12	447-26	Head Gasket	1	38	445-412-1	Low Pressure Piston & Pin Assy.	1
13	SS-26	3/8 " - 16 x 1 1/2" Hex Head Cap Screw	7	39	445-9403	High Pressure Rod & Piston Assy.	1
14	357-9701	Air Filter Replacement Cartridge	1	40	445-9402	Low Pressure Rod & Piston Assy.	1
15	ACC-9010	3/4 " Compression Fittings	1	41	KK-9805	Ring Kit	1
16	SS-31	3/8 "-16 x 2 1/2" Hex Head Cap Screw	2	42	SS-6045	Set Screw 3/8" - 16 x 1 1/2"	5
17	TIA-5075	75 lb Safety Valve	1	43	445-89	Valve Plug	5
18	SS-9922	3/8-16 x 7/8 Socket Screw	4	44	SS-7424-ZN	Cap Nut 3/8" - 16	5
19	447-330	Intercooler	1	45	VRK-247	Valve Repair Kit	1
20	235-23	Ball Bearing	2	46	445-4205	Exhaust Valve Assy.	2
21	445-5-1	Oil Throw Ring	2	47	357-9401	Air Filter/Silencer Assy.	1
22	45817-514	Crankshaft & Oil Cup Assy.	1	48	447-24	Cylinder Head	1
23	235-43	Oil Cup	2	49	445-196	Intercooler Gasket	2
24	432-13	End Plate Gasket	1	50	SS-01767	Gasket	5
25	342-160	Felt Washer	1	51	445-4217	Intake Valve Assy.	3
26	37333-305	End Plate	1				

Service Kits & Regular Maintenance Items

- VRK-247** Valve Repair Kit - Kit includes valve discs, jam & cap nuts, valve springs, set screws and valve gaskets (ref.# 45)
- OK-247** Overhaul Kit - Kit includes gasket kit (GK-9404), ring kit (KK-9805), valve repair kit (VRK-247), bearing inserts (445-474) and an oil seal (342-111)
- GK-9404** Gasket Kit - Kit includes all gaskets (ref.# 2, 9, 12, 24, 49, 50 and all valve gaskets)
- MK-247** Maintenance Kit - Kit includes 3L of oil (PR-20) and air filter (357-9701)
- PR-20** Premium Compressor Oil - For operating temperatures below 90°F
- PR-30** Premium Compressor Oil - For operating temperatures above 90°F

CPR-9700 Centrifugal Pressure Release

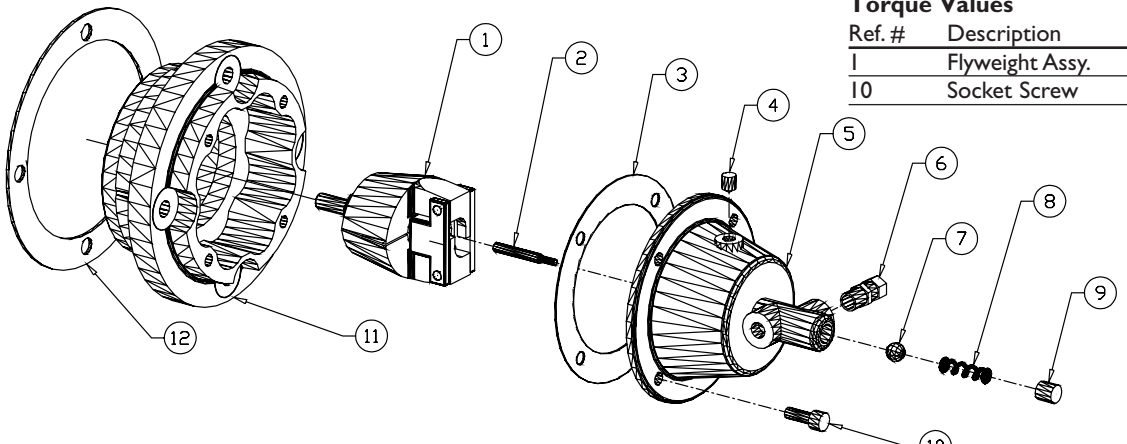

Torque Values

Ref. #	Description	In. lbs.	Ft. lbs.	Nm
1	Flyweight Assy.	288	24	32.5
10	Socket Screw	96	8	10.8

1	CPR-9401	Plunger/Flyweight assy.	5	CPR-9009	Valve/cup body	9	CPR-9000	Plug/guide
2	CPR-9004	Valve Stem	6	SS-8553	Compression Fitting	10	SS-10022	Socket Head Screw
3	445-144	Gasket	7	CPR-9007	Ball	11*	37333-306	CPR Housing
4	CPR-9000-1	Plug	8	CPR-9006	Valve Spring	12*	432-12	Gasket

CPR Repair Kit: CPR-9010 includes # 2, 3, 7, 8, 9

*NOTE: these parts are required when converting a non-CPR pump to a CPR pump, and are not included in CPR-9700

Chart 1
Compressor Torque Values
(When SAE20 oil is used as a lubricant)

Ref. No.	Description	In. lbs.	Ft. lbs.	Nm
4	Small end plate	144	12	16.2
4	Large end plate	144	12	16.2
7	Oil ring retainer	144	12	16.2
37	Connecting rod	408	34	46
10	Cylinder to crankcase	564	47	63.7
13 & 16	Head bolts	360	30	40.6
31	Flywheel bolts	1860	155	210
43	Valve plug	1500	125	169
42	Valve set screw	180	15	20.3
44	Cap nuts	180	15	20.3
18	Intercooler Bolt	240	20	27.1
45	Valves	180	15	20.3

NOTE: Retorque head bolts, cylinder bolts, intercooler and end plates after first 10 hours of operation.

In.lbs. Inch Pounds
Ft.lbs. Foot Pounds
Nm Newton Meters

Chart 2
Honing Specifications

Cylinder	Std. Hone Dia.	Skirt/Cyl. Dia. clearance
Low pressure cylinder	4.5000/4.5005	.0065/.0085
High pressure cylinder	2.5000/2.5005	.0025/.0045

1. Cylinder must be within diametral tolerance at all points, out of round or taper must not exceed .005.
2. Hone, 20 min. to 35 max. micro inches of surface roughness.
3. De-burr the sharp corners at the top and bottom of the cylinder opening with a 1/64 to 1/32 x 30 degree chamfer.

Chart 3
Connecting Rod Insert Bearings

Insert	Crank Throw Dia.	Part No.
Std.	2.2490/2.2485	445-474
0.02 Oversize	2.2290/2.2285	445-474-020

CAUTION: Pre-lubricate all crank throws and insert bearing surfaces to prevent compressor tie up during the first few minutes of operation. Pour some oil on the outside of the connecting rod and crank shoulders. Use the crankcase oil, DO NOT USE GREASE.

Compressor Dimensions

